

Grease separator EasyClean free UnderSink, NS 0,7

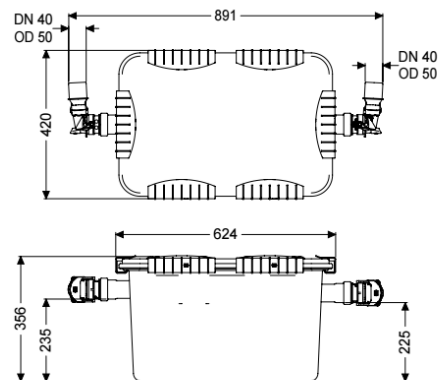
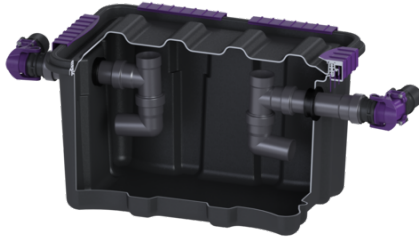

Article information

Item no.: 93070.00US
 GTIN: 4026092096857
 Price group: 60

Advantages

- Swivel connection
- no internal metallic components in the separator

Description

This separator for greasy waste water is suitable for freestanding installation in frost-protected rooms below a sink. Free of any metal components, the collecting tank is made of durable plastic (PP) equipped with an integrated sludge trap. An odor-tight lid with a wrap-around seal and closure clip allows easy access during manual emptying and cleaning. The separator also has quick-release pipe connections for easy removal, and an inspection window for on-site installation is available as an option for visually checking the thickness of the grease layer.

Variant

Seal:	yes
Sludge bucket:	no
Nominal size (NS):	0,7
Refill inlet in accordance with DIN 1988:	no
Type of disposal:	manual
Sampling device:	no

General characteristics

Material:	PP
Installation situation:	free-standing installation
Delivery state:	Modular set for assembly on site

Dimensions

Net weight:	5,9 kg
Gross weight:	5,9 kg
Operating weight:	38 kg

Empty weight:	5 kg
Set-up area, length:	891 mm
Set-up area, width:	420 mm
Set-up area, height:	356 mm
Required access area, length:	624 mm
Packaging dimension:	length
Packaging dimension:	width
Packaging dimension:	height

Tank/drain body

Distance pipe bottom outlet to tank bottom:	225 mm
Distance pipe bottom inlet to tank bottom:	235 mm
Outlet nominal size (OD):	50 mm
Outlet nominal size (DN):	50 mm
Inlet nominal size (OD):	50 mm
Inlet nominal size (DN):	50 mm

Coverage features

Locking:	Clip closure
----------	--------------

Wastewater contents

Separator contents:	21 l
Max. grease layer thickness:	57 mm
Total volume:	33 l
Contents of sludge trap:	12 l
Storage quantity of grease:	8 l