



# KG-System (PVC-U)

## Installation-Instructions

### 1. SCOPE AND AREA OF APPLICATION

#### 1.1 Scope

The following instructions apply for the utilisation and installation of KG pipes and fittings made of PVC-U in accordance with DIN EN 1401, or DIN EN 13476-2(pipes). Colour: orange/brown, RAL 8023, which, as a buried ground sewer system, sewer connection and sewer piping system serves to drain off waste water. In the case of piping within buildings, the guidelines on the application of combustible building materials in building construction and the respective assembly instructions for building drainage pipe installations are to be observed.

#### 1.2 Area of application

Sewer pipes and sewer fittings made of PVC-U are used to drain away waste water. In the case of DN/OD 110 to 200, temperatures may not be constantly higher than 45° C, and in the case of DN/OD 250 to 600 they may not be constantly higher than 35° C. PVC sewer pipes and fittings are suitable for the drainage of chemically aggressive water in the region of pH 2 (acid) to pH 12 (basic). They are resistant to household waste water in accordance with DIN 1986-3. For the drainage of industrial waste water, both DIN 8062 and the supplement sheet no. 1 for DIN 8061 are to be observed.

##### 1.2.1 Area of application without a static indication

Utilisation of KG SN 4 pipes and fittings made of PVC-U without static indication is permissible under the following conditions:

- Traffic load does not exceed bridge category 30 in accordance with DIN 1072.
- Minimum cover of 1.00 m under traffic surfaces and a minimum cover of 0.80 m under traffic-free surfaces or such surfaces which are only sometimes subject to light traffic.
- Maximum cover of 6.00 m on bedding in ditches with a width of at least those which are in compliance with DIN 4124 without traffic load; a maximum cover of 4.00 m in far wider ditches and under embankments without traffic load; and a maximum cover of 3.50 in far wider ditches and under embankments under traffic surfaces.
- Bedding material in the area of the pipes:  $\gamma < 20.5 \text{ kN/m}^3$ ,  $\gamma \geq 22.5^\circ$  soil constants in accordance with DIN 1055, Part 2, Tables 1 and 2 taking into consideration binding mixed soils as in sections 5 and 6. In unfavourable cases, the following soils in accordance with DIN 18196 may be included as far as this aspect is concerned: Gravel and silt mixture, Gravel and clay mixture, Sand and silt mixture, Sand and clay mixture.
- Requirement in accordance with DIN EN 1610. Bedding in the region of ground water may only be carried out when it has been ensured that no movement of the filling material can occur (e.g. bedding in a gravel filter layer or concrete).

##### 1.2.2 Area of application with a static indication

Should there be any deviations from the abovementioned conditions, a static indication has to be made, and the project questionnaire has to be filled out (see <https://www.ostendorf-kunststoffe.com/services/statikberechnung-objektbogen>). Vertical deformation of the pipes once they have been installed and are under stress may, in accordance with DIN EN 1610, not exceed 6%.

## 2. TRANSPORTING AND STORING PVC PIPES AND PIPING COMPONENTS

The piping components are to be transported with suitable vehicles and are to be properly loaded and unloaded. During transport, the entire length of the pipes should be supported if possible, in order to avoid sagging. Severe impact stress is to be avoided, particularly in temperatures around freezing point. Pipes and fittings may be stored outdoors. The following measures must be observed on storing pipes:

- The pipes must be stored in such a manner that perfect support is ensured and that no deformation can occur.
- The layers of pipes can be stored both with or without wood in between the layers.
- On storing, pipe sockets should be horizontally and vertically unhampered.
- The stack height should not exceed 2 m. Rubber sealing elements, insofar as these are not protected by a coat of finishing varnish, may not be stored outdoors for a long period.

### 2.1 Supporting and embedding

The supporting and embedding of pipes and fittings made of PVC-U in the case of buried ground piping are of vital significance and must therefore be carried out with great care in accordance with DIN EN 1610. In the case of concrete casings for PVC pipes, it must be ensured that the casing is produced in such a manner that it can support itself alone without the pipe. When bedding the pipes in the region of groundwater, care must be taken that the filling material does not move (e.g. embedding in a gravel filterlayer or in concrete).

On bedding in soil under foundations, there must be a minimum cover of 150 mm over the socket. In the case of direct burdening by construction components, protective pipes must be laid if necessary.

#### Demonstration of the terms

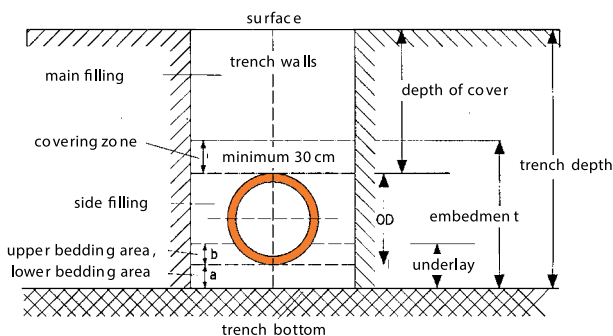

### 2.2 Installation procedure

Each pipe and fitting is to be levelled according to drop and direction. A straight, continuous path in the stipulated slope is to be observed. In exceptional cases DN/OD 110 to 200 pipes can be installed as indicated in the following diagram. The data indicated on the following tables, may, however not be exceeded.

#### Gauges h max. or bending radius R in m at a length L of:

DN/OD	110	125	160	200	250	315
8 m	0,24	0,21	0,17	0,13	0,11	0,08
12 m	0,54	0,48	0,38	0,30	0,24	0,19
16 m	0,97	0,85	0,67	0,53	0,42	0,34
R	33	38	47	61	75	95

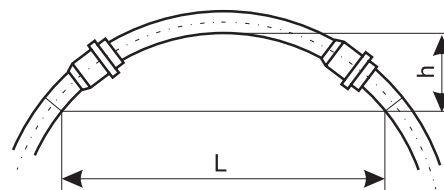

As an alternative to the information in the chart, a deflection of the pipe connection of 1 ° may be implemented in the KG-PVC system with the factory inserted seal in accordance with DIN EN 681.

### 2.3 Embedding in concrete

Pipes and fittings made of hard PVC may be embedded direct in concrete. However, the following instructions are to be observed:

- Cover the socket gap with adhesive tape so that no grout can seep in, which may then hinder the subsequent functioning of the sliding socket.
- Protect the pipes against uplifting. The intervals between fixing points are to be carried out in such a manner that unduly substantial sagging can occur (formation of water traps).
- Take into consideration any thermal changes in length, both on instalment and also in use (plastic pipes which have been cemented in react in the same manner as those which are not covered).

### 2.4 Cutting to length and slanted cutting

If necessary, the pipes may be cut to length (fittings may not be shortened since there is no guarantee that they will still be watertight) with a suitable plastic cutter or a finetoothed saw. By means of guiding the saw through a cutting frame as illustrated, a right-angled cut can be achieved. For larger pipe cuttings, a cutting disc suitable for PVC can be used. The cutting edges must be trimmed. The pipe ends must be slanted at an angle of approx. 15° in accordance with the diagram, using suitable tools for slanting or a coarse file.

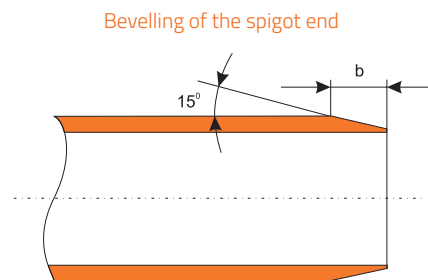

Approximate measurement

DN/OD	110	125	160	200	250	315	400	500
<b>b mm ca.</b>	6	6	7	9	9	12	15	18

## 3. PRODUCING A CONNECTION FOR PIPES AND FITTINGS SLIDING SOCKET

### 3.1 Glued sockets (single sockets)

For other uses, lengths of pipes can be fitted with glued sockets. The following is to be observed:

- Removal of the sawing burr
- Cleaning any dirt off the pipe from the outside and the single socket from the inside.
- Applying the special glue to the cleaned surfaces
- Pushing the glued socket onto the pipe until it resists
- Wiping off any excessive glue

The glue will take about one hour to set. However, the pipes should only be subjected to tension (pressure testing) after 3-4 hours. The THF glue must comply with DIN 16970.

The THF glue must comply with the guideline R.1.1.7 of the Gütegemeinschaft Kunststoffrohr e. V. and DIN 16970.

## 3.2 Sliding socket

The pipe sleeve, the spigot end of the pipe and the seal must be checked for damage and cleaned before the connection process. Damaged pipes or seals may not be used or must be replaced.

- Remove any dirt from the outside of the inserting end (spigot end), from the inside of the sockets and sealing chamber (corrugation) and from the sealing ring itself with a cloth.
- Insert the sealing ring into the corrugation (should this not already have been done at the plant).
- Coat the slant of the inserting end evenly with a lubricant. Do not use any oils or greases!
- Push the inserting end into the sliding socket until it resists and make a marking on the edge of the socket with a pencil or a felt-tip pen. Finally the pipe end must be pulled out of the socket approx. 3 mm per metre of installed total length, but must be pulled out at the most 10 mm. Installing sleeve sockets and twin sockets is carried out in the same manner.

## 4. CONNECTION WITH PIPES MADE OF OTHER MATERIALS

### 4.1.1 Connecting cast iron insertion ends to PVC sewer pipes and fittings

If cast piping ends with an insertion end, the PVC piping is connected to the cast pipe insertion end with the connection piece KGUG. The PVC connector (KGUG) is always delivered without gasket. The GA gasket set or the sleeve must be ordered separately.

Push the sleeve onto the cast iron pipe spigot, then push the PVC connector (KGUG) onto the cast iron spigot with the sleeve. The A-ring is a rolling ring and is used to safely guide the spigot of the pipe. The G-ring is used for sealing. First pull the A-ring onto the cast iron spigot, then fit the G-ring onto the rim of the cast iron spigot. Push the PVC connector (KGUG) onto the cast iron spigot with the GA rings.

#### Cast-iron pipe – spigot end

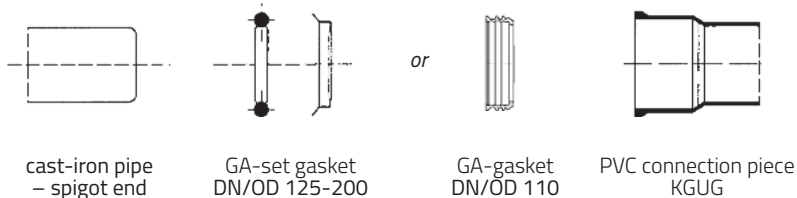

### Connecting cast iron sockets to PVC sewer pipes and fittings

If cast piping ends with a socket, the PVC piping is connected to the cast iron pipe socket without any connection piece. Put the sleeve onto the PVC spigot. Push the PVC spigot together with the sleeve into the cast iron pipe socket. The A-ring is a rolling ring and is used to safely guide the pipe spigot. The G-ring is used for sealing. First pull the A-ring onto the PVC spigot, then fit the G-ring onto the rim of the PVC spigot. Push the PVC spigot together with the GA rings into the cast iron pipe socket.

#### Cast-iron pipe – socket

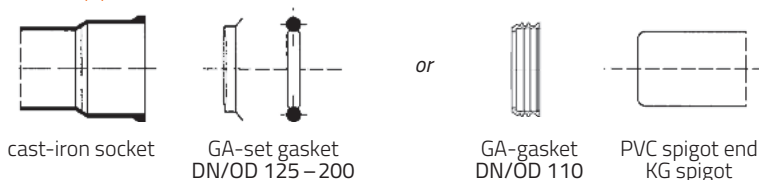

### 4.1.2. Connecting PVC sewer pipes and fittings to clay pipes with socket

If clay piping ends with a socket, the PVC piping is connected to the clay pipe socket with the connection piece KGUSM. The connection is sealed with the clay pipe roll ring, which is mounted onto the connection piece and inserted into the clay pipe socket.

#### Stoneware pipe – socket for roller ring

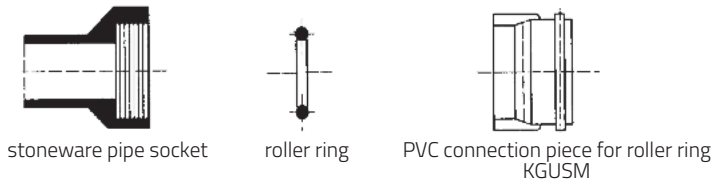

#### 4.1.3 Connecting PVC sewer pipes and fittings to clay pipes with an L sliding socket

If clay piping ends with an L sliding socket, the PVC piping is connected to the clay pipe socket (KGUSM) with a connecting piece. The connecting piece is pushed into the sliding socket and no additional sealing is required.

#### stoneware pipe – socket L

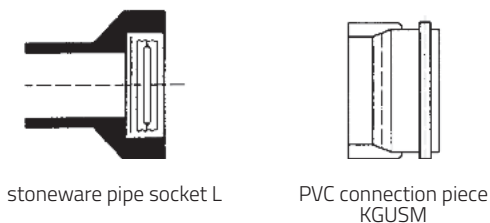

#### 4.1.4 Connection of vitrified clay pipe spigots of the standard load series to PVC sewer pipes and fittings

If clay piping ends with an insertion end, the PVC piping is connected to the clay pipe insertion end (KGUS) with a connecting piece. Sealing takes place with a KGUS sleeve.

#### stoneware pipe – spigot end

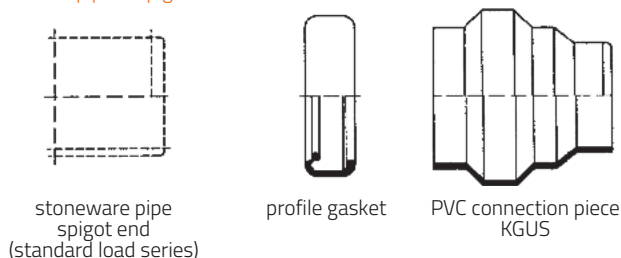

#### 4.2 Check of waterproofness for watertightness

Vertical pipes or suitable pressure meters are to be used in order to carry out checks. Readings are to be taken at the lowest point on the area to be tested. Non-pressure pipes are to be tested with 0.5 bar excess pressure, measured at the lowest point in the area of piping to be tested which is covered by water. Testing time is 15 minutes. The test is to be carried out on piping which has not yet been covered. In order to secure the location, the piping can be embedded and partly covered (filling cone), with pipe connections remaining uncovered. If necessary, the piping is to be protected against floating. All openings of the section of piping to be checked, including all branches and junctions, are to be closed in such a manner that they are watertight and secure against pressure.

#### 4.3 Filling and sealing

On both sides of the piping, stone-free, compressible soil (maximum granule size 20 mm Ø) is to be layered up to 0.30 m and compressed either manually or with the help of light machines. The piping may not be pushed to the side. If necessary, soil should be filled in and compressed simultaneously from both sides. The vertical position of smaller DN(OD) pipes is to be secured during the embedding procedure. The degree of compaction of the soil in the region of the pipes presumed in the structural analysis is to be produced by means of adequate compression. This is to be proved on request (for example, by means of gauging the Proctor density or by means of driving bores). In exceptional cases, for example when ditches are narrow and do not permit sufficient compressing of the embedding in the supporting area, the piping can be partly or fully installed with concrete or similar materials. Further filling in is then to take place layer-by-layer up to a height of 0.30 m over the pipe crown.

## 5. SUBSEQUENT CONNECTION TO PVC SEWER PIPES

### 5.1 Installing a branch (procedure I)

In order to install a branch, a sufficiently long piece of pipe (length of the fittings + 2 d) is removed ❶, the pipe-ends are trimmed, cut at an angle and the branch is inserted. Sleeve sockets, with which the piping is once again closed, are pushed over both the other half of the pipe and over the adjusting piece to be inserted ❷ + ❸.

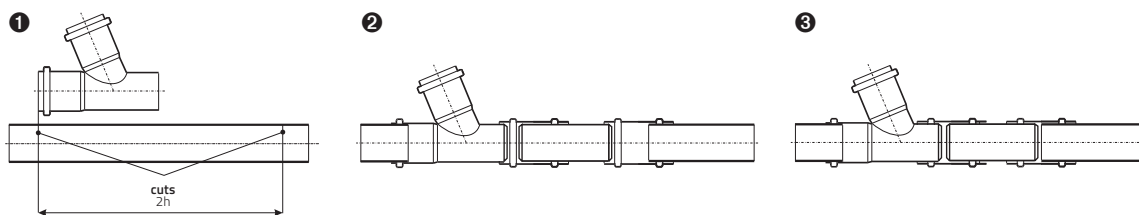

### 5.2 Inserting a branch (procedure II)

A piece of pipe equivalent to the total length of the branch plus a length approximately equivalent to  $d/5$  is cut out of the piping at hand by means of cross section cuts ❷.

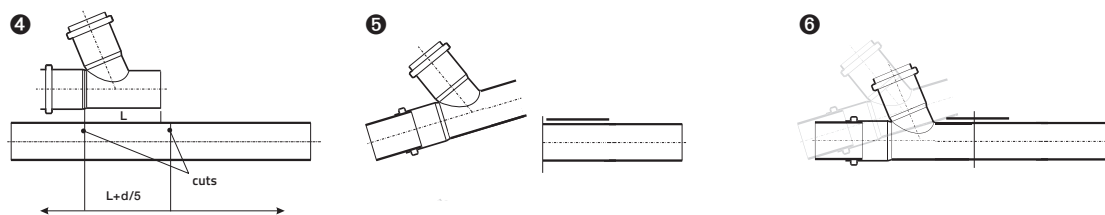

Both pipe ends are trimmed and slanted. A sleeve socket is then pushed over one end and the other pipe end is cautiously levered out, the branch is pushed on ❸ and the end of the pipe with the branch is brought back into the original position. The connection is made by means of pushing back the sleeve socket on the cut between the pipe and the fittings spigot end ❹.

### 5.3 General requirements on pipes, fittings and connections

If pipes without factory-made sockets, for example rest lengths or cutted pipes, are installed, it is recommended to use double sockets as connection piece. Couplers are only to be used for renovation resp. repair purposes. In case that within one pipe line components of different product standards are used please note that they have to be connected by standardized or approved adaptor pieces and sealings.

**Gebr. Ostendorf Kunststoffe GmbH**  
 Rudolf-Diesel-Straße 6–8 · D-49377 Vechta  
 Tel. +49 (0) 4441 874-10 · Fax +49 (0) 4441 874-15  
 verkauf@ostendorf-kunststoffe.com

[www.ostendorf-kunststoffe.com](http://www.ostendorf-kunststoffe.com)

