

# 2011.0200

Corner 2011

The drain unit has two wall flanges and one floor flange.



## Specifications

<b>ITEM NUMBER</b>	<b>GTIN NUMBER</b>	<b>WEIGHT INCLUDING PACKAGING</b>
2011.0200	5707692006659	900 g
<b>WEIGHT EXCLUDING PACKAGING</b>	<b>MATERIAL</b>	<b>USAGE</b>
700 g	1,5 mm stainless steel (AISI 304)	Corner drain
<b>SURFACE</b>	<b>MEMBRANE</b>	<b>FLOOR CONSTRUCTION</b>
Pickled	Liquid or sheet membrane	All
<b>FLOORING</b>	<b>MOUNTING</b>	<b>INSTALLATION LENGTH (L1)</b>
Tiles	6 mm plugs 6 mm screws. Torx 20	377 mm
<b>INSTALLATION LENGTH (L2)</b>		
267 mm		

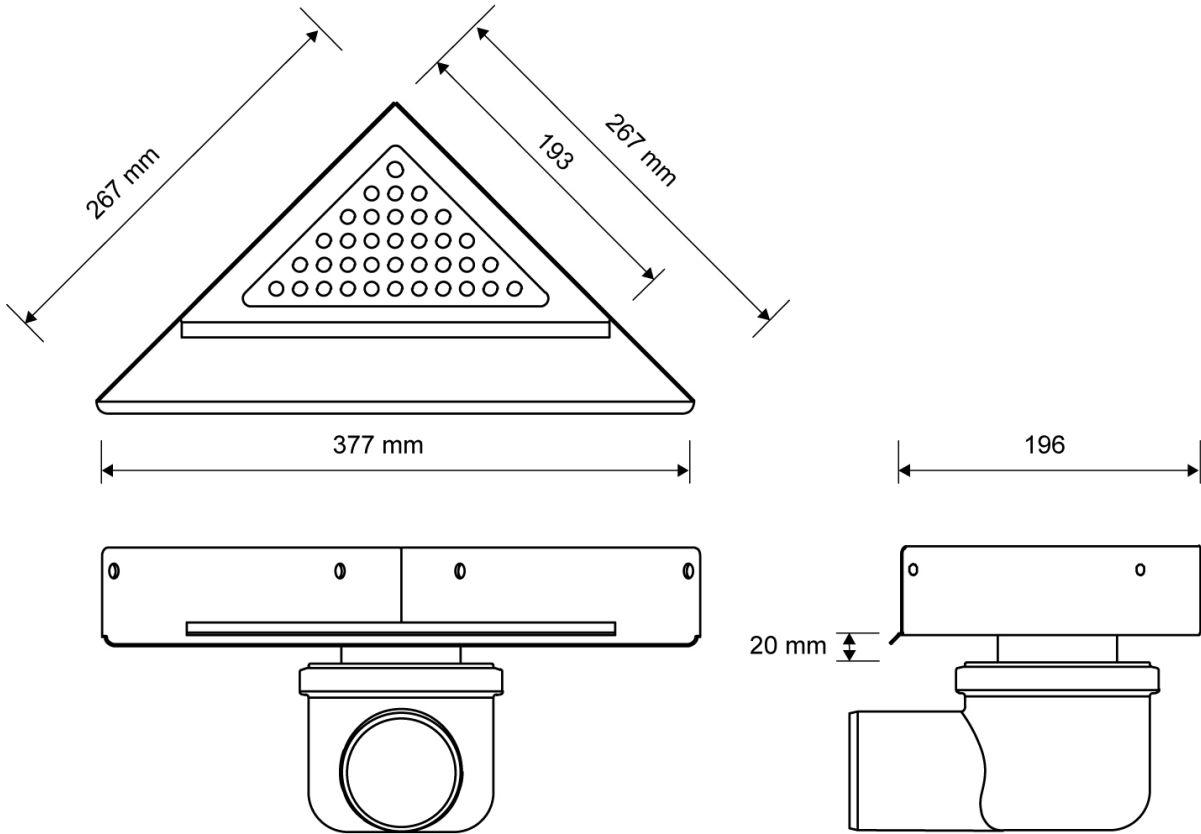

**2011.0200**

Products